

# Cylindrical

## PXM18 Series



Appearance

Sensing type	Diffuse reflection		
Sensing distance	10cm(fixed)	40cm(fixed)	
Hysteresis	≤10%		
Repeat accuracy	5%		
Output type	NPN/PNP Open-collector		
Switch type	Selectable L.on/D.on		
Response frequency	250Hz		
Indicator	Red LED(660nm)	Red LED(880nm)	
Operating voltage	10~30V DC(± 10%)		
Voltage drop	2V max 1L=100mA		
Leakage current	1 μA		
Current consumption	30mA		
Load current	100mA		
Protective circuit	Reverse polarity protection, output short circuit protection, pulse overvoltage protection		
Ambient temperature	-25°C~+70°C, No freezing		
Ambient brightness	Sunlight ≤10000 lux, Incandescent lamp ≤3000 lux		
Degree of protection	IP67		
Tightening torque	1Nm		
Material	Housing: PBT, Lens: PC		
Weight	≈ 50g		
Connection method	2M 4core cable		
Model No.	NPN	<b>PXM18-D10N</b>	<b>PXM18-D40N</b>
	PNP	<b>PXM18-D10P</b>	<b>PXM18-D40P</b>

### Dimensions

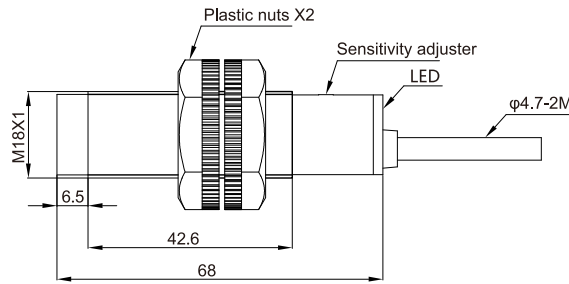

Unit: mm

### Circuit diagram

#### NPN Output

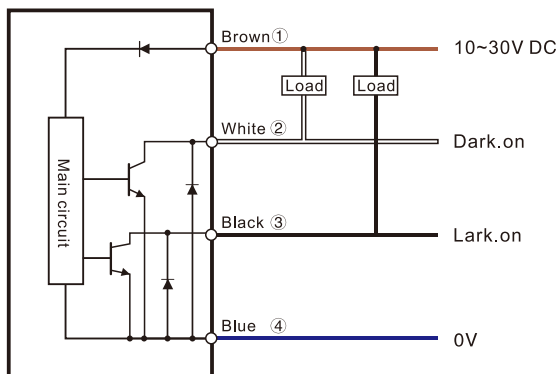

#### PNP Output

