

Anti-glare Type

PTL Series



Anti-glare Type

NEW!

Appearance		
Sensing type	Diffuse reflection-BGS	
Sensing distance	5~100mm	10~300mm
Sensing distance	20~100mm	50~300mm
Spot diameter	≈ Ø10mm/100mm	≈ Ø30mm/300mm
Should be bad	≦3%	≦5%
Output type	NPN / PNP open collector	
Switch Type	L.on/D.on selectable	
Indicator	Operating indicator: orange, Status indicator: red	
Response time	≦1ms	
Sensitivity	6-turn potentiometer	4-turn potentiometer
Light source	Red LED	
Operating voltage	10~30V DC	
Current consumption	≦30mA	
Ambient light	Sunlight ≦ 50,000 Lux, Incandescent lamp ≦ 5,000 Lux	
Ambient temperature	-25°C~+55°C, No freezing	
Ambient humidity	35%~85%RH, No condensation	
Anti-vibration	10 to 50 Hz with 0.5mm amplitude for 2 hours each in X, Y, and Z directions	
Degree of protection	IP67	
Connection	ABS (body), PMMA (window)	
Accessories	Screwdriver	
Model No.	NPN PTL-D10N PNP PTL-D10P	PTL-D30N PTL-D30P

Dimensions

Unit: mm

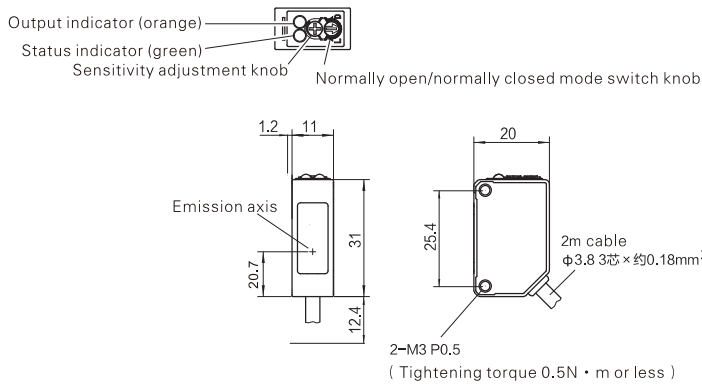

Circuit diagram

NPN Output

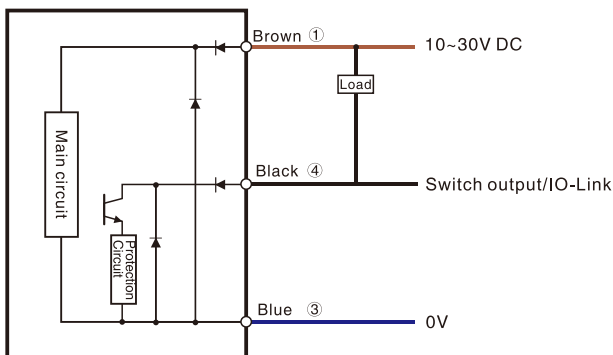

PNP Output

